

**A Project Report on**

**PREVENTION OF ACCIDENTS BY EYE BLINKING DETECTION METHOD**

*A Project report submitted for the partial fulfillment of the*

*Requirements for the award of*

**“BACHELOR OF TECHNOLOGY”**

IN

**ELECTRONICS AND INSTRUMENTATION ENGINEERING**

BY

A.SABARISH KUMAR	(10091A1074)
K.RAVI	(10091A1068)
C .SIVA GAYATHRI	(10091A1083)
N.MANIKANTA	(11095A1002)
K.NAVEEN	(11095A1003)

**Under the Esteemed Guidance of**

**Dr.K.MURALIDHARA REDDY** M.Sc(Phy),M.Sc(Inst),Ph.d(Inst)

(Professor and HOD)



**DEPARTMENT OF ELECTRONICS AND INSTRUMENTATION ENGINEERING**

**RAJEEV GANDHI MEMORIAL COLLEGE OF ENGINEERING & TECHNOLOGY**

**(AUTONOMOUS)**

**Affiliated to JNTU, Anantapur, Accredited by NBA, New Delhi, Accredited by NAAC with 'A' Grade Approved by AICTE New Delhi, Participated in world Bank Aided TEQIP.**

**NANDYAL -518501, A.P.**

**2010-2014**

**RAJEEV GANDHI MEMORIAL COLLEGE OF ENGINEERING AND  
TECHNOLOGY NANDYAL, A.P.**

**(AUTONOMOUS)**

**Affiliated to JNTU, Anantapur, Accredited by NBA, New Delhi, Accredited by NAAC with  
'A' Grade Approved by AICTE New Delhi, Participated in world Bank Aided TEQIP.**

**NANDYAL -518501, A.P.**

**2010-2014**

**CERTIFICATE**

This is to certify that the project report entitled

**PREVENTION OF ACCIDENTS BY EYE BLINKING DETECTION METHOD**

**Submitted by**

A.SABARISH KUMAR	(10091A1074)
K.RAVI	(10091A1068)
C .SIVA GAYATHRI	(10091A1083)
N.MANIKANTA	(11095A1002)
K.NAVEEN	(11095A1003)

In the partial fulfillment of the requirement for the award of the degree of **Bachelor of Technology** in **Electronics and Instrumentation Engineering** of **Jawaharlal Nehru Technological University-Anantapur** is a record of bonafide work carried out by them in this Department.

**Head of the Department:**

**Dr.K.MURALIDHARA REDDY**

MSC (Phy), MSC (Inst), Ph.D (Inst)

**Professor & HOD**

Dept of E.I.E

**Project Guide:**

**Dr.K.MURALIDHARA REDDY**

MSC (Phy), MSC (Inst), Ph.D (Inst)

**Professor & HOD**

Dept of E.I.E

Examiner:

Date:



# ACKNOWLEDGEMENTS

All endeavors over a long period can be successful only with the advice and support of many well wishers. We take this opportunity to express our gratitude and appreciation to all of them.

At the outset we thank our honorable chairman **Dr.SANTHI RAMUDU** for providing us with good faculty and for his moral support Throughout the course.

Involuntarily, we are perspicuous to divulge our sincere gratefulness to our principal, **Dr.T.JAYACHANDRA PRASAD** garu who has been observed posing valiance in abundance forwards.

We express our gratitude to **Dr.MURALIDHARA REDDY** garu Head of the Department, Electronics and Instrumentation Engineering for the encouragement and assistance to us, which contribute to the successful completion of this project.

We manifest our heartier thankfulness pertaining to our contentment over **Mr.K.MURALIDHARA REDDY** garu, **Professor and HOD** , Dept. of Electronics and Instrumentation Engineering as a project guide with adroit concomitance the excellence has been exemplified in bringing out this project work with artistry.

We express our heart full thanks to our advisers **Mr.P.V.GOPI KRISHNA RAO** garu and **LECTURERS, Department Of E.I.E, R.G.M.C.E.T, NANDYAL** for their warm encouragement and valuable suggestions.

It would be incomplete without thanking all **OUR FRIENDS** who helped us sharing their knowledge and by providing material to complete the project in time.

Finally, a word of gratitude to **OUR BELOVED PARENTS** who have been a constant source of encouragement and love .

# DECLARATION

We hereby declare that the mini project work entitled "PREVENTION OF ACCIDENTS BY EYE BLIKING DETECTION METHOD" submitted to the Rajeev Gandhi Memorial college of Engineering and Technology affiliated to JNTU Anaparthi, is a record of an original work done by us under the guidance of Mr.K.MURALIDHARA REDDY, Professor and HOD, Dept. of Electronics and Instrumentation Engineering. This project work is submitted in the partial fulfillment of the requirement for the award of degree of BACHELOR OF TECHNOLOGY in ELECTRONICS AND INSTRUMENTATION ENGINEERING. The results embodied in this thesis have not been submitted to any other university or institute for the award of any degree or diploma/fellowship and similar project if any.

## PROJECT ASSOCIATES

A.SABARISH KUMAR(10091A1074)

C .SIVA GAYATHRI(10091A1083)

N.MANIKANTA(11095A1002)

K.RAVI(10091A1068)

K.NAVEEN(11095A1003)



# CHAPTER - 1

## INTRODUCTION

### INTRODUCTION:

*“Driving to save lives, time, and money in spite of the conditions around you and the actions of others.”*- This is the slogan for Defensive Driving.

The aspiration for this desired dream of automation in automobiles is derived from many sources dreams and wishes. Many times the process of transport had been so burdensome that we wish we would fall asleep during the journey. Our automobile is one such car which is awakes the driver from sleep

Vehicle accidents are most common if the driving is inadequate. These happen on most factors if the driver is drowsy or if he is alcoholic. Driver drowsiness is recognized as an important factor in the vehicle accidents. It was demonstrated that driving performance deteriorates with increased drowsiness with resulting crashes constituting more than 20% of all vehicle accidents. But the life lost once cannot be re-winded. Advanced technology offers some hope avoid these up to some extent.

Road traffic accidents kill more than 120 lakh people and injured more than 50 Crore people worldwide every year. Everyday about 6600 deaths and 3300 serious injuries occur due to RTAs.

### 1.1 Some Statistics for India:

- In India, 1,20,000 people die and 12,70,000 sustain serious injuries every year in Road Traffic Accidents.
- As per the statistics, there is one death on the Indian road for every six minutes and this is expected to escalate to one death every three minutes by 2020
- Even this may be an underestimation, as according to the Institute of Road Traffic Education (2006) Institute of road education, New Delhi, out of the estimated 1.4

- million serious road accidents occurring annually in India, hardly 0.4 million are recorded. (*Indian Journal of Neurotrauma (IJNT) 2008, Vol. 5, No. 2, pp. 63-67*)
- India accounts for about 10% of road accident fatalities worldwide
- According to the experts at the National Transportation Planning and Research Centre (NTPRC) the number of road accidents in India is 3 times higher than that prevailing in developed countries.
- The number of accidents for 1000 vehicles in India is as high as 35 while the figure ranges from 4 to 10 in developed countries
- World Health Organization has revealed in its first ever Global Status Report on Road Safety (2009) that more people die in road accidents in India than anywhere else in the world, including the more populous China.

## 1.2 Socio-Economic Implications of Road Accidents

- National crime records Bureau statistics show 13 people die in our country every hour due to RTAs. 85 % of the victims of these fatalities are men in the age group 20-50 years. Majority of these men are the bread- winners for their families.
- Physical disability resulting from RTAs also hugely impacts the society. For example, spinal cord injury permanently disables the patient resulting in him/her being confined to wheel chair or bed for the rest of their life. The plight of their family is similar to, if not worse, than those of the fatally injured.
- The following chart shows the accident scenario from year 1970-2011.

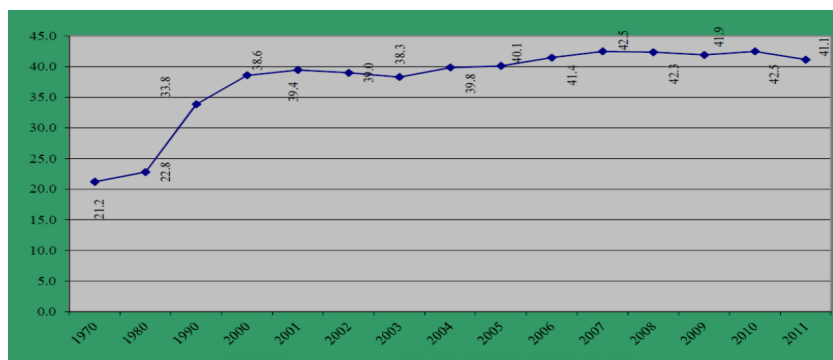

**Figure1.1: Number of road accidents per lakh population (1970-2011)**



(\*data source : Ministry of road transport and highways, Gov. of India, New Delhi)

## CHAPTER - 2

### AIM AND SCOPE

#### 2.1 AIM:

This project aims at

- 1) Building an instrument that wakes the driver when he is drowsy
- 2) Reducing the speed of the vehicle if the person doesn't wake with alarm
- 3) Displaying a message at the back of the vehicle indicating " STOP EMERGENCY"

In the first part, we are going to wake the driver by triggering an alarm.

In the second part, we are going to stop the vehicle by retarding its speed with the help of a motor driver.

In the third part a message "STOP EMERGENCY" will be displayed as an indication to the other vehicles, that the vehicle is going to stop.

#### 2.2 Scope:

The instrument developed for Prevention of accidents by blinking detection method is a prototype. It can be manufactured with less cost and is easy to integrate. Thus it enables the manufacturer to design safer vehicles to avoid the majority of accidents which are due to drowsiness of the driver.

This can be integrated with alcohol detector which avoids the "DRUNK AND DRIVE"





# **CHAPTER 3**

## **MATERIAL & EXPERIMENTAL**

### **METHOD**

#### **3.1 Block diagram and overview**

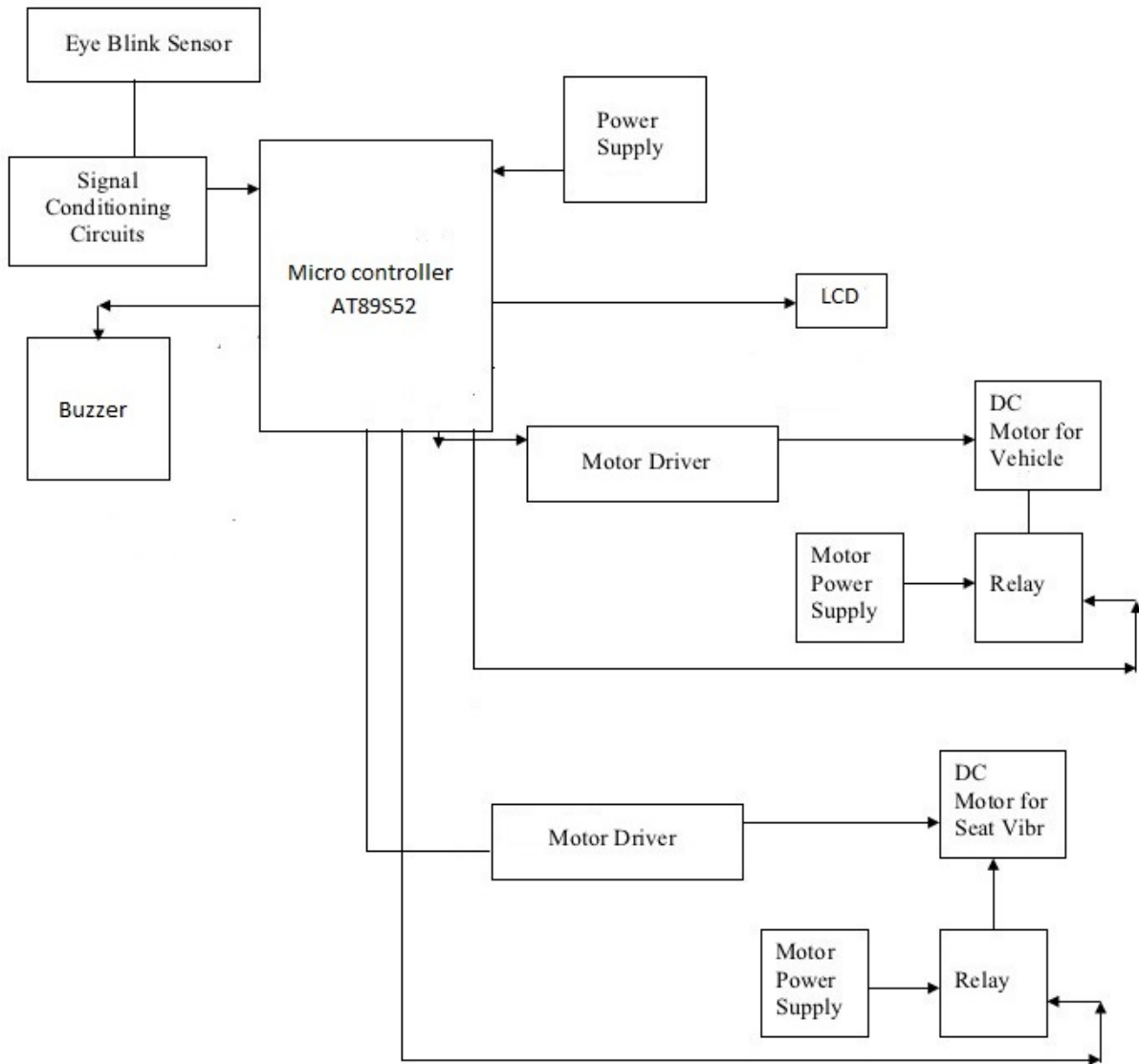

(Power supply is given to all units)

Fig 3.1:Block diagram

## MICROCONTROLLER



## 4.1 Microcontroller:

A micro controller (sometimes abbreviated MCU) is a small computer on a single integrated circuit containing a processor core, memory, and programmable input/output peripherals. Program memory in the form of NOR flash or OTP ROM is also often included on chip ,as well as a typically small amount of RAM. Microcontrollers are designed for embedded applications in contrast to the microprocessors used in personal computers or other general purpose applications.

## 4.2 History :

The first microprocessor was the 4-bit Intel 4004 released in 1971, with the Intel 8008 and other more capable microprocessors becoming available over the next several years. However, both processors required external chips to implement a working system, raising total system cost, and making it impossible to economically computerize appliances.

The Smithsonian Institution says TI engineers Gary Boone and Michael Cochran succeeded in creating the first microcontroller in 1971. The result of their work was the TMS 1000, which went commercial in 1974. It combined read-only memory, read/write memory, processor and clock on one chip and was targeted at embedded systems.

Partly in response to the existence of the single-chip TMS 1000, Intel developed a computer system on a chip optimized for control applications, the Intel 8048, with commercial parts first shipping in 1977. It combined RAM and ROM on the same chip. This chip would find its way into over one billion PC keyboards, and other numerous applications. At that time Intel's President, Luke J. Valenter, stated that the microcontroller was one of the most successful in the company's history, and expanded the division's budget over 25%.

Most microcontrollers at this time had two variants. One had an erasable EPROM program memory, with a transparent quartz window in the lid of the

package to allow it to be erased by exposure to ultraviolet light. The other was a PROM variant which was only programmable once; sometimes this was signified with the designation OTP, standing for “one-time programmable”. The PROM was actually exactly the same type of memory as the EPROM, but because there was no way to expose it to ultraviolet light, it could not be erased. The erasable versions required ceramic packages with quartz windows, making them significantly more expensive than the OTP versions, which could be made in lower-cost opaque plastic packages. For the erasable variants, quartz was required, instead of less expensive glass, for its transparency to ultraviolet—glass is largely opaque to UV—but the main cost differentiator was the ceramic package itself.

In 1993, the introduction of EEPROM memory allowed microcontrollers (beginning with the Microchip PIC16x84) to be electrically erased quickly without an expensive package as required for EPROM, allowing both rapid prototyping, and In System Programming. (EEPROM technology had been available prior to this time, but the earlier EEPROM was more expensive and less durable, making it unsuitable for low-cost mass-produced microcontrollers.) The same year, Atmel introduced the first microcontroller using Flash memory, a special type of EEPROM.<sup>[3]</sup> Other companies rapidly followed suit, with both memory types.

### 4.3 AT89s52:



**Fig.4.3.AT89s52 IC**

The AT89S52 is a low-power, high-performance CMOS 8-bit microcontroller with 8K bytes of in-system programmable Flash memory. The device is manufactured using



Atmel's high-density nonvolatile memory technology and is compatible with the industry-standard 80C51 instruction set and pinout. The on-chip Flash allows the program memory to be reprogrammed in-system or by a conventional nonvolatile memory programmer. By combining a versatile 8-bit CPU with in-system programmable Flash on a monolithic chip, the Atmel AT89S52 is a powerful microcontroller which provides a highly-flexible and cost-effective solution to many embedded control applications. The AT89S52 provides the following standard features: 8K bytes of Flash, 256 bytes of RAM, 32 I/O lines, Watchdog timer, two data pointers, three 16-bit timer/counters, a six-vector two-level interrupt architecture, a full duplex serial port, on-chip oscillator, and clock circuitry. In addition, the AT89S52 is designed with static logic for operation down to zero frequency and supports two software selectable power saving modes. The Idle Mode stops the CPU while allowing the RAM, timer/counters, serial port, and interrupt system to continue functioning. The Power-down mode saves the RAM contents but freezes the oscillator, disabling all other chip functions until the next interrupt or hardware reset.

#### **4.3.1 Features:**

Compatible with MCS®-51 Products

- 8K Bytes of In-System Programmable (ISP) Flash Memory

– Endurance: 10,000 Write/Erase Cycles

4.0V to 5.5V Operating Range

- Fully Static Operation: 0 Hz to 33 MHz
- Three-level Program Memory Lock
- 256 x 8-bit Internal RAM
- 32 Programmable I/O Lines
- Three 16-bit Timer/Counters



- Eight Interrupt Sources
- Full Duplex UART Serial Channel
- Low-power Idle and Power-down Modes
- Interrupt Recovery from Power-down Mode
- Watchdog Timer
- Dual Data Pointer
- Power-off Flag
- Fast Programming Time
- Flexible ISP Programming (Byte and Page Mode)

#### 4.3.2 Pin diagram:

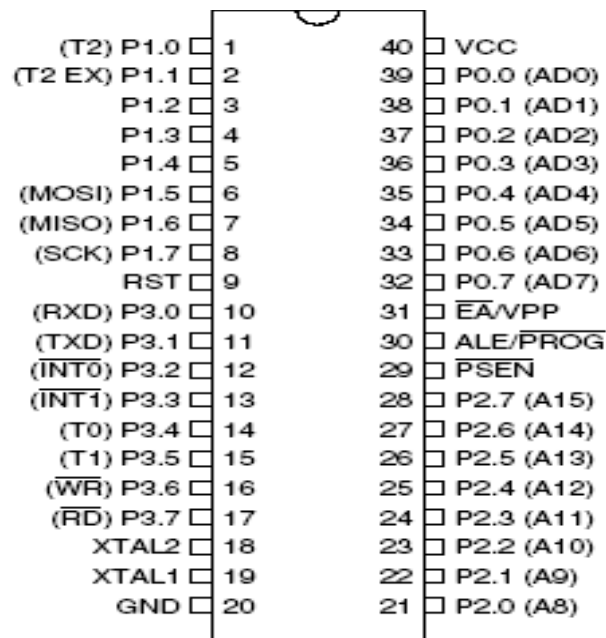



### 4.3.3 Pin description:

#### **VCC:**

Supply voltage.

#### **GND :**

Ground.

#### **Port0:**

Port 0 is an 8-bit open drain bidirectional I/O port. As an output port, each pin can sink eight TTL inputs. When 1s are written to port 0 pins, the pins can be used as high-impedance inputs. Port 0 can also be configured to be the multiplexed low-order address/data bus during accesses to external program and data memory. In this mode, P0 has internal pull-ups. Port 0 also receives the code bytes during Flash programming and outputs the code bytes during program verification. External pull-ups are required during program verification.

#### **Port1 :**

Port 1 is an 8-bit bidirectional I/O port with internal pull-ups. The Port 1 output buffers can sink/source four TTL inputs. When 1s are written to Port 1 pins, they are pulled high by the internal pull-ups and can be used as inputs. As inputs, Port 1 pins that are externally being pulled low will source current (IIL) because of the internal pull-ups.

In addition, P1.0 and P1.1 can be configured to be the timer/counter 2 external count input (P1.0/T2) and the timer/counter 2 trigger input (P1.1/T2EX), respectively, as shown in the following table.

Port 1 also receives the low-order address bytes during Flash programming and verification.



**Table.4.3.3: pins of port1**

Port pin	Alternate functions
P1.0	T2 (external count input to timer/counter2),clock-out
P1.1	T2EX (timer/counter2 capture/reload trigger and direction control )
P1.5	MOSI(used in-system programming)
P1.6	MISO(used for in-system programming)
P1.7	SCK(used for in-system programming)

**Port2 :**

Port 2 is an 8-bit bidirectional I/O port with internal pull-ups. The Port 2 output buffers can sink/source four TTL inputs. When 1s are written to Port 2 pins, they are pulled high by the internal pull-ups and can be used as inputs. As inputs, Port 2 pins that are externally being pulled low will source current (IIL) because of the internal pull-ups. Port 2 emits the high-order address byte during fetches from external program memory and during accesses to external data memory that use 16-bit addresses (MOVX @ DPTR). In this application, Port 2 uses strong internal pull-ups when emitting 1s. During accesses to external data memory that use 8-bit addresses (MOVX @ RI), Port 2 emits the contents of the P2 Special Function Register.

Port 2 also receives the high-order address bits and some control signals during Flash programming and verification.

**Port3:**





Port 3 is an 8-bit bidirectional I/O port with internal pull-ups. The Port 3 output buffers can sink/source four TTL inputs. When 1s are written to Port 3 pins, they are pulled high by the internal pull-ups and can be used as inputs. As inputs, Port 3 pins that are externally being pulled low will source current (IIL) because of the pull-ups.

Port 3 receives some control signals for Flash programming and verification.

Port 3 also serves the functions of various special features of the AT89S52, as shown in the following table.

**Table.4.3.3:Pins of port3**

Port pin	Alternate functions
P3.0	RXD(serial input port)
P3.1	TXD(serial interrupt)
P3.2	INT0 (external interrupt 0)
P3.3	INT1 (external interrupt 1)
P3.4	T0 (timer 0 external input)
P3.5	T1 (timer 1 external input)
P3.6	WR (external data memory write strobe)
P3.7	RD (external data memory read strobe)

**RST :**

Reset input. A high on this pin for two machine cycles while the oscillator is running resets the device. This pin drives high for 98 oscillator periods after the Watchdog times out. The DISRTO bit in SFR AUXR (address 8EH) can be used to disable this feature. In the default state of bit DISRTO, the RESET HIGH out feature is enabled.

**ALE/PROG:**

Address Latch Enable (ALE) is an output pulse for latching the low byte of the address during accesses to external memory. This pin is also the program pulse input (PROG) during Flash programming.



In normal operation, ALE is emitted at a constant rate of 1/6 the oscillator frequency and may be used for external timing or clocking purposes. Note, however, that one ALE pulse is skipped during each access to external data memory.

If desired, ALE operation can be disabled by setting bit 0 of SFR location 8EH. With the bit set, ALE is active only during a MOVX or MOVC instruction. Otherwise, the pin is weakly pulled high. Setting the ALE-disable bit has no effect if the microcontroller is in external execution mode.

### **PSEN:**

Program Store Enable (PSEN) is the read strobe to external program memory. When the AT89S52 is executing code from external program memory, PSEN is activated twice each machine cycle, except that two PSEN activations are skipped during each access to external data memory.

### **EA/VPP:**

External Access Enable. EA must be strapped to GND in order to enable the device to fetch code from external program memory locations starting at 0000H up to FFFFH. Note, however, that if lock bit 1 is programmed, EA will be internally latched on reset. EA should be strapped to VCC for internal program executions. This pin also receives the 12-volt programming enable voltage (VPP) during Flash programming.

### **XTAL1:**

Input to the inverting oscillator amplifier and input to the internal clock operating circuit.

### **XTAL2:**

Output from the inverting oscillator amplifier.

### **Special Function Registers :**



Note that not all of the addresses are occupied, and unoccupied addresses may not be implemented on the chip. Read accesses to these addresses will in general return random data, and write accesses will have an indeterminate effect.

User software should not write 1s to these unlisted locations, since they may be used in future products to invoke new features. In that case, the reset or inactive values of the new bits will always be 0.

Timer 2 Registers: Control and status bits are contained in registers T2CON and T2MOD for Timer 2. The register pair (RCAP2H, RCAP2L) are the Capture/Reload registers for Timer 2 in 16-bit capture mode or 16-bit auto-reload mode.

**Interrupt Registers:** The individual interrupt enable bits are in the IE register. Two priorities can be set for each of the six interrupt sources in the IP register.

Memory Organization MCS-51 devices have a separate address space for Program and Data Memory. Up to 64K bytes each of external Program and Data Memory can be addressed.

## Program Memory

If the EA pin is connected to GND, all program fetches are directed to external memory. On the AT89S52, if EA is connected to VCC, program fetches to addresses 0000H through 1FFFH are directed to internal memory and fetches to addresses 2000H through FFFFH are to external memory.

## Data Memory:

The AT89S52 implements 256 bytes of on-chip RAM. The upper 128 bytes occupy a parallel address space to the Special Function Registers. This means that the upper 128 bytes have the same addresses as the SFR space but are physically separate from SFR space. When an instruction accesses an internal location above address 7FH, the address mode used in the instruction specifies whether the CPU accesses the upper 128 bytes of RAM or the SFR space. Instructions which use direct



addressing access the SFR space. For example, the following direct addressing instruction accesses the SFR at location 0A0H (which is P2). `MOV 0A0H, #data` Instructions that use indirect addressing access the upper 128 bytes of RAM. For example, the following indirect addressing instruction, where R0 contains 0A0H, accesses the data byte at address 0A0H, rather than P2 (whose address is 0A0H). `MOV @R0, #data` Note that stack operations are examples of indirect addressing, so the upper 128 bytes of data RAM are available as stack space.

### **Watchdog Timer (One-time Enabled with Reset-out):**

The WDT is intended as a recovery method in situations where the CPU may be subjected to software upsets. The WDT consists of a 14-bit counter and the Watchdog Timer Reset (WDTRST) SFR. The WDT is defaulted to disable from exiting reset. To enable the WDT, a user must write 01EH and 0E1H in sequence to the WDTRST register (SFR location 0A6H). When the WDT is enabled, it will increment every machine cycle while the oscillator is running. The WDT timeout period is dependent on the external clock frequency. There is no way to disable the WDT except through reset (either hardware reset or WDT overflow reset). When WDT over-flows, it will drive an output RESET HIGH pulse at the RST pin.

### **Using the WDT:**

To enable the WDT, a user must write 01EH and 0E1H in sequence to the WDTRST register (SFR location 0A6H). When the WDT is enabled, the user needs to service it by writing 01EH and 0E1H to WDTRST to avoid a WDT overflow. The 14-bit counter overflows when it reaches 16383 (3FFFH), and this will reset the device. When the WDT is enabled, it will increment every machine cycle while the oscillator is running. This means the user must reset the WDT at least every 16383 machine cycles. To reset the WDT the user must write 01EH and 0E1H to WDTRST. WDTRST is a write-only register. The WDT counter cannot be read or written. When WDT overflows, it will generate an output RESET pulse at the RST pin. The RESET pulse duration is  $98 \times TOSC$ , where  $TOSC = 1/FOSC$ . To make the best use of the WDT, it should be serviced in those sections of code that will periodically be executed within the time required to prevent a WDT reset.



## **WDT During Power-down and Idle :**

In Power-down mode the oscillator stops, which means the WDT also stops. While in Power-down mode, the user does not need to service the WDT. There are two methods of exiting Power-down mode: by a hardware reset or via a level-activated external interrupt which is enabled prior to entering Power-down mode. When Power-down is exited with hardware reset, servicing the WDT should occur as it normally does whenever the AT89S52 is reset. Exiting Power-down with an interrupt is significantly different. The interrupt is held low long enough for the oscillator to stabilize. When the interrupt is brought high, the interrupt is serviced. To prevent the WDT from resetting the device while the interrupt pin is held low, the WDT is not started until the interrupt is pulled high. It is suggested that the WDT be reset during the interrupt service for the interrupt used to exit Power-down mode. To ensure that the WDT does not overflow within a few states of exiting Power-down, it is best to reset the WDT just before entering Power-down mode. Before going into the IDLE mode, the WDIDLE bit in SFR AUXR is used to determine whether the WDT continues to count if enabled. The WDT keeps counting during IDLE (WDIDLE bit = 0) as the default state. To prevent the WDT from resetting the AT89S52 while in IDLE mode, the user should always set up a timer that will periodically exit IDLE, service the WDT, and reenter IDLE mode. With WDIDLE bit enabled, the WDT will stop to count in IDLE mode and resumes the count upon exit from IDLE.

## **Interrupts:**

The AT89S52 has a total of six interrupt vectors: two external interrupts (INT0 and INT1), three timer interrupts (Timers 0, 1, and 2), and the serial port interrupt. These interrupts are all shown in Figure 13-1. Each of these interrupt sources can be individually enabled or disabled by setting or clearing a bit in Special Function Register IE. IE also contains a global disable bit, EA, which disables all interrupts at once. Note that Table 13-1 shows that bit position IE.6 is unimplemented. User software should not write a 1 to this bit position, since it may be used in future AT89 products. Timer 2 interrupt is generated by the logical OR of bits TF2 and EXF2 in register T2CON.



Neither of these flags is cleared by hardware when the service routine is vectored to. In fact, the service routine may have to determine whether it was TF2 or EXF2 that generated the interrupt, and that bit will have to be cleared in software. The Timer 0 and Timer 1 flags, TF0 and TF1, are set at S5P2 of the cycle in which the timers overflow. The values are then polled by the circuitry in the next cycle. However, the Timer 2 flag, TF2, is set at S2P2 and is polled in the same cycle in which the timer overflows.

**Table4.3.3: Interrupt Enable (IE) Register**

EA	---	ET2	ES	ET1	EX1	ET0	EX0
----	-----	-----	----	-----	-----	-----	-----

Enable Bit = 1 enables the interrupt.

Enable Bit = 0 disables the interrupt.

Symbol	Position	Function
EA	IE.7	Disable all interrupts. If EA=0, no interrupt is acknowledged. If EA=1, each interrupt source is individually enabled or disabled by setting or clearing its enable bit.
---	IE.6	Reserved
ET2	IE.5	Timer2 interrupt enable bit
ES	IE.4	Serial port interrupt enable bit
ET1	IE.3	Timer1 interrupt enable bit
EX1	IE.2	External interrupt 1 enable bit
ET0	IE.1	Timer0 interrupt bit
EX0	IE.0	External interrupt 0 enable bit



### 3.3 SENSORS USED

#### IR SENSORS

##### INTRODUCTION:

An infrared sensor is an electronic instrument that is used to sense certain characteristics of its surroundings by either emitting and/or detecting infrared radiation. It is also capable of measuring heat of an object and detecting motion. Infrared waves are not visible to the human eye.

In the electromagnetic spectrum, infrared radiation is the region having wavelengths longer than visible light wavelengths, but shorter than microwaves. The infrared region is approximately demarcated from 0.75 to 1000 $\mu\text{m}$ . The wavelength region from 0.75 to 3 $\mu\text{m}$  is termed as near infrared, the region from 3 to 6 $\mu\text{m}$  is termed mid-infrared, and the region higher than 6 $\mu\text{m}$  is termed as far infrared.

Infrared technology is found in many of our everyday products. For example, TV has an IR detector for interpreting the signal from the remote control. Key benefits of infrared sensors include low power requirements, simple circuitry, and their portable feature.

##### Types of Infra-Red Sensors

Infra-red sensors are broadly classified into two types:

**Thermal infrared sensors** – These use infrared energy as heat. Their photo sensitivity is independent of wavelength. Thermal detectors do not require cooling; however, they have slow response times and low detection capability.

**Quantum infrared sensors** – These provide higher detection performance and faster response speed. Their photo sensitivity is dependent on wavelength. Quantum detectors have to be cooled so as to obtain accurate measurements. The only exception is for detectors that are used in the near infrared region.

There are different types of IR sensors working in various regions of the IR spectrum but the physics behind "IR sensors" is governed by three laws:

##### 1. *Planck's radiation law:*

Every object at a temperature T not equal to 0 K emits radiation. Infrared radiant energy is determined by the temperature and surface condition of an object. Human eyes cannot detect differences in infrared energy because they are primarily sensitive to visible light energy from 400 to 700 nm. Our eyes are not sensitive to the infrared energy.

## 2. *Stephan Boltzmann Law*

The total energy e emitted at all wavelengths by a black body is related to the absolute temperature as

$$W_b = \sigma T^4$$

Where,  $W_b$ : Total energy emitted

$\sigma$ : Constant =  $5.67 \times 10^{-8} \text{m}^{-2}\text{K}^{-4}$

T: Temperature of the object

## *Wein's Displacement Law*

Wein's Law tells that objects of different temperature emit spectra that peak at different wavelengths. It provides the wavelength for maximum spectral radiant emittance for a given temperature.

### *Active IR sensors:*

- *Reflectance Sensors*

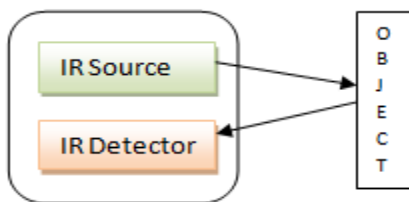

**Fig 3.3.1:IR signals hitting object**

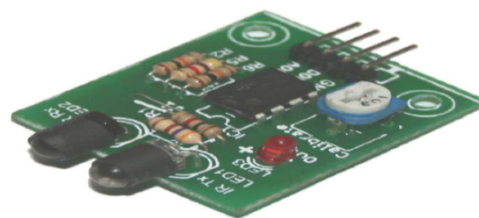

**Fig 3.3.2: ir sensor board**

### *Specifications:*

- Range of around 2 cm
- Input Voltage: 5V DC
- Comes with an easy to use digital output





- Can be used for wireless communication and sensing IR remote signals
- Sensor comes with ambient light protection

## Working Principle

The sensor provides a digital and an analog output. The sensor outputs a logic one(+5V) at the digital output when an object is placed in front of the sensor and a logic zero(0V), when there is no object in front of the sensor. An onboard LED is used to indicate the presence of an object. The sensor outputs an analog voltage between 0V and 5V, corresponding the distance between the sensor and the object at the analog output. The analog output can be hooked to an ADC to get the approximate distance of the object from the sensor. IR sensors are highly susceptible to ambient light and the IR sensor on this sensor is suitably covered to reduce effect of ambient light on the sensor. The sensor has a maximum range of around 40-50 cm indoors and around 15-20 cm outdoors.

## Applications

- The following are the key application areas of infrared sensors:
- Tracking and art history
- Climatology, meteorology, and astronomy
- Thermography, communications, and alcohol testing
- Heating, hyperspectral imaging, and night vision
- Biological systems, photobiomodulation, and plant health
- Gas detectors/gas leak detection
- Water and steel analysis, flame detection
- Anesthesiology testing and spectroscopy

## 3.4 DC MOTORS AND MOTOR DRIVERS

### History and Back ground:

At the most basic level, electric motors exist to convert electrical energy into

mechanical energy. This is done by way of two interacting magnetic fields -- one stationary, and another attached to a part that can move. A number of types of electric motors exist, but mostly used DC motors in some form or another. DC motors have the potential for very high torque capabilities (although this is generally a function of the physical size of the motor), are easy to miniaturize, and can be "throttled" via adjusting their supply voltage. DC motors are also not only the simplest, but the oldest electric motors.

The basic principles of electromagnetic induction were discovered in the early 1800's by Oersted, Gauss, and Faraday. By 1820, Hans Christian Oersted and Andre Marie Ampere had discovered that an electric current produces a magnetic field. The next 15 years saw a flurry of cross-Atlantic experimentation and innovation, leading finally to a simple DC rotary motor. A number of men were involved in the work, so proper credit for the first DC motor is really a function of just how broadly you choose to define the word "motor."

## DC MOTORS

DC motors are the device that converts electrical energy into mechanical energy. Now days DC motors are playing a vital role in industries and real life. Here in the DC motor the supply voltage  $E$  & current  $I$  are given as input to the motor and we derive the mechanical output. Torque  $T$  speed  $\omega$  at output port.

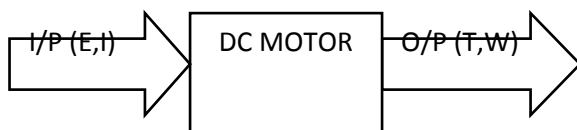

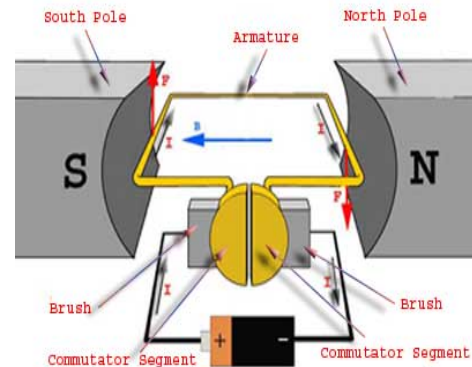

**Fig :3.4.1: block diagram of DC motor**

**Fig : 3.4.2 Parts of DC motor**

In order to understand the operating principle of the DC motor we need to first look in to the constructional feature. The basic construction of a DC motor contains a current carrying armature which is connected to supply ends through commutator segment and is placed between north and south pole of an permanent or electro-magnet.

**PRINCIPLE:**

This DC works on the principle, when a current carrying conductor is placed in a magnetic field; it experiences a torque and has a tendency to move. This is known as motoring action. If the direction of electric current in the wire is reversed, the direction of rotation also reverses. When magnetic field and electric field interact they produce a mechanical force, and based on that the working principle of dc motor established.

The direction of rotation of a this motor is given by *Fleming's left hand rule*, which states that if the index finger, middle finger and thumb of your left hand are extended mutually perpendicular to each other and if the index finger represents the direction of magnetic field, middle finger indicates the direction of electric, then the thumb represents the direction in which force is experienced by the shaft of the *dc motor*.

The magnitude of force F is given by

$$F = B i L \text{ newton } , \text{ where}$$

$B$  is the magnetic field in weber/m<sup>2</sup>.

$i$  is the current in amperes and

$L$  is the length of the coil in meter.

The force, current and the magnetic field are all in different directions.

The torque produced is given by *Torque = force, tangential to the direction of armature rotation*  $\times$  *distance*.

$T = BIL w \cos\alpha$ , Where  $\alpha$  is the angle between the plane of the armature turn and the plane of reference

**DC motor operation:**

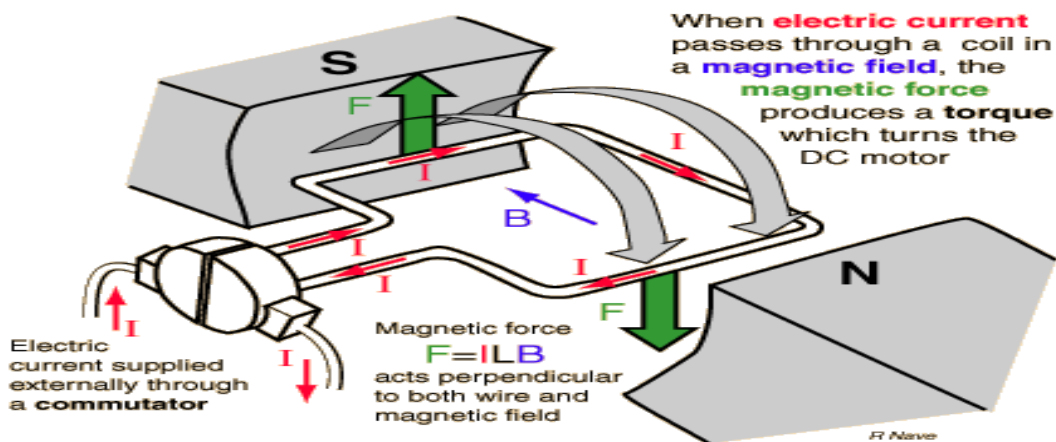

**Fig 3.4.3 : DC motor operation**

**Current in DC Motor :**

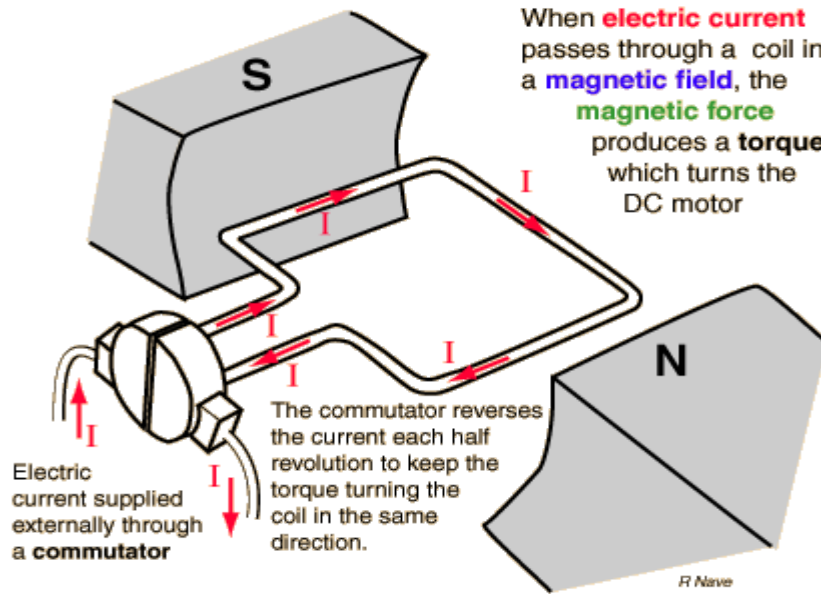

**Fig :3.4.4: current in the DC motor**

### **Magnetic Field in DC motor**

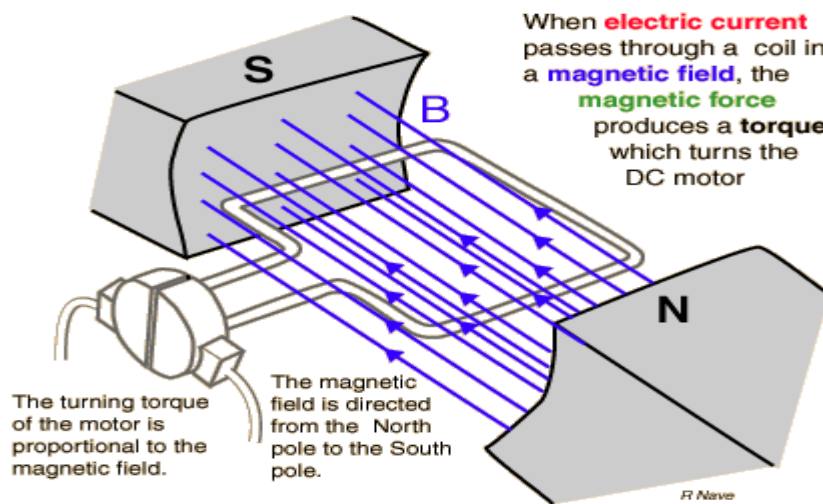

**Fig:3.4.5:Magnetic field in DC motor**

### **SPECIFICATIONS**

diameter:from 6mm to 50mm  
Speed: 1-1000RPM



MaxTorque: 80 kg.cm  
low speed

### 3.4.2 L293D Motor Driver

This is a medium power motor driver perfect for driving DC Motors and Stepper Motors. It uses the popular L293 motor driver IC. It can drive 4 DC motors on and off, or drive 2 DC motors with directional and speed control. The driver greatly simplifies and increases the ease with which you may control motors, relays, etc from microcontrollers.

It can drive motors from 4.5 v to 36V with a total DC current of up to 600mA. You can connect the two channel in parallel to double the maximum current or in series to double the maximum voltage.

This motor driver uses screw terminals for easy connections, mounting holes for easy mounting, back EMF protection circuit, onboard heat sink for better heat dissipation and more efficient performance.

This motor driver is perfect for robotics and mechatronics projects for controlling motors from microcontrollers, switches, relays, etc. Perfect for driving DC and stepper motors for micromouse line following robots, robot arms, etc.

The direction and speed of each DC Motor can be controlled through three control pins marked En x, INP x1 & INP x2 on the board where x is the motor to be controlled (A or B). To drive a motor, the Enable pin (En x) should be provided a logic high (5V). The direction of the motors is controlled by the other two Input pins. Providing a logic high signal to INP x1 and logic zero (0V) to INP x2 will drive the motor in one direction and providing logic high to INP x2 and logic zero to INP x1 will drive the motor in the opposite direction. Providing logic high to both the input pins will cause the motor to brake and providing logic zero to both the input pins, will cause the motor to rotate freely.

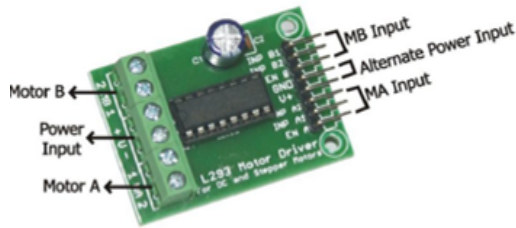

**Fig:3.4.6:L293 motor driver board**

**Features:**

- Maximum motor supply voltage: 4.5V - 36V
- Maximum motor supply current: 600 mA per motor
- Onboard Heat sink for better performance
- The driver two holes of 3mm diameter for easy mounting

**Pin connections and motor direction:**

The table below shows the control pin status and motor direction corresponding to the status of input pins.

**Table :3.4.1: Control pin status and motor direction of L293 motor board**

EN X	INP X1	INP X2	Motor Direction
High	High	Low	Clockwise
High	Low	High	Anti-clockwise
High	Low	Low	Free Rotation
High	High	High	Brake
Low	Any	Any	Free Rotation



For the operation of the motor, the enable pin should always be high. The direction can be decided by selecting appropriate logic for the INPX1 and INPX2. When the i/p 1 is high and i/p2 low, the motor will rotate in clockwise direction and vice versa. If the i/p1 and i/p2 are both high then the motor will have a brake and if both are high then the motor will rotate freely.

### 3.4.3 ULN 2803

The eight NPN Darlington connected transistors in this family of arrays are ideally suited for interfacing between low logic level digital circuitry (such as TTL, CMOS or PMOS/NMOS) and the higher current/voltage requirements of lamps, relays, printer hammers or other similar loads for a broad range of computer, industrial, and consumer applications. All devices feature open-collector outputs and freewheeling clamp diodes for transient suppression.

The ULN2803 is designed to be compatible with standard TTL families while the ULN2804 is optimized for 6 to 15 volt high level CMOS or PMOS.

#### Features:

- Output current (single output) :500 mA (max)
- High sustaining voltage output :50 V (min)
- Output clamp diodes
- Inputs compatible with various types of logic.
- Package Type-APG: DIP-18pin
- Package Type-AFWG: SOP-18pin

**Maximum Ratings** (TA = 25°C and rating apply to any one device in the Package, unless otherwise noted)

**Table:3.4.2: Maximum ratings of ULN2803**



Rating	Symbol	Value	Unit
Output Voltage	$V_O$	50	V
Input Voltage (Except ULN2801)	$V_I$	30	V
Collector Current – Continuous	$I_C$	500	mA
Base Current – Continuous	$I_B$	25	mA
Operating Ambient Temperature Range	$T_A$	0 to +70	°C
Storage Temperature Range	$T_{stg}$	-55 to +150	°C
Junction Temperature	$T_J$	125	°C

$R_{\theta JA} = 55^\circ\text{C/W}$ , Do not exceed maximum current limit per driver.

Pin Configuration:

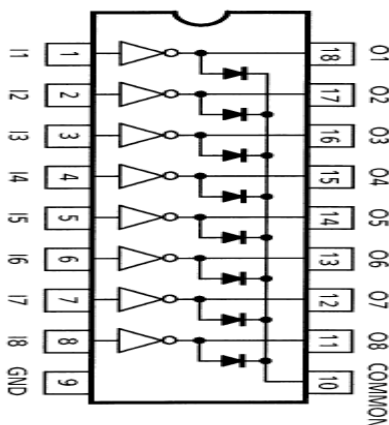

**Fig:3.4.7: pin configuration of ULN2803**

ULN Board:



**Fig :3.4.8: ULN driver board**

**Schematic (each Darlington pair)**

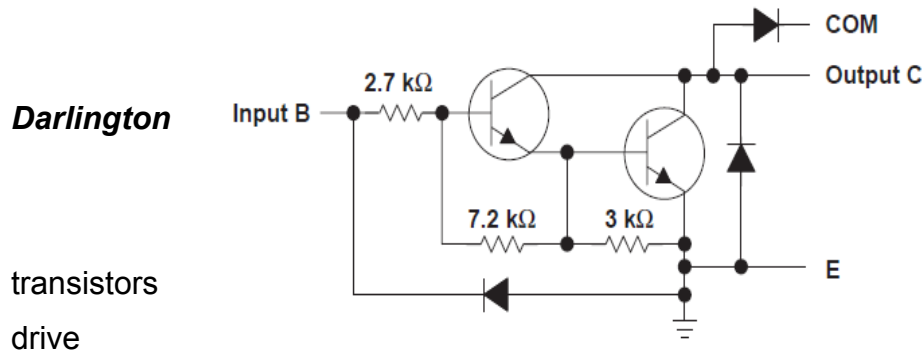

**Fig :3.4.9:**  
**pair**

transistors  
drive

Individual  
can be used to  
higher power

output components such as motors and lamps. Sometimes it is necessary to drive a number of outputs at a time. Instead of using many transistors, integrated circuits are available that contain a number of transistors. These are called *Darlington arrays* and two such components are the ULN2803. The advantage of transistor arrays is that it allows much smaller circuit board to be designed since a single chip takes up less space on a PCB than a number of separate transistors.

**Electrical characteristics at 25°C free-air temperature (unless otherwise noted):**

**Table :3.4.3.1: Electrical charecteristics of ULN2803 at 25°C**



PARAMETER		TEST CONDITIONS	MIN	TYP	MAX	UNIT
$I_{CEX}$	Collector cutoff current	$V_{CE} = 50\text{ V}$ , $I_I = 0$ , See Figure 1			50	$\mu\text{A}$
$I_{I(off)}$	Off-state input current	$V_{CE} = 50\text{ V}$ , $I_C = 500\ \mu\text{A}$ , $T_A = 70^\circ\text{C}$ , See Figure 2	50	65		$\mu\text{A}$
$I_{I(on)}$	Input current	$V_I = 3.85\text{ V}$ , See Figure 3		0.93	1.35	mA
$V_{I(on)}$	On-state input voltage	$V_{CE} = 2\text{ V}$ , See Figure 4	$I_C = 200\text{ mA}$		2.4	V
			$I_C = 250\text{ mA}$		2.7	
			$I_C = 300\text{ mA}$		3	
$V_{CE(sat)}$	Collector-emitter saturation voltage	$I_I = 250\ \mu\text{A}$ , See Figure 5	$I_C = 100\text{ mA}$		0.9	V
			$I_C = 200\text{ mA}$		1	
			$I_C = 350\text{ mA}$		1.3	
$I_R$	Clamp diode reverse current	$V_R = 50\text{ V}$ , See Figure 6			50	$\mu\text{A}$
$V_F$	Clamp diode forward voltage	$I_F = 350\text{ mA}$ , See Figure 7		1.7	2	V
$C_i$	Input capacitance	$V_I = 0\text{ V}$ , $f = 1\text{ MHz}$		15	25	pF

### 3.4.4 About the Driver board:

We can drive two motors using the ULN2803 driver board. We have to give the input for the board at the input side indicated and the output is collected at the corresponding pins i.e. if we give input at the pin3, the corresponding output is collected at the pin3 on output side. In order to drive the board we can give the supply ranging from 3.3V to 12V to the first pin of the board while the second pin is given to the ground. The main advantage of ULN is that we can have precise speed control of the motors.

### 5.3 Applications of dc motor:

- Industrial applications use dc motors because the speed-torque relationship can be varied to almost any useful form for both dc motor and regeneration applications in either direction of rotation. Continuous operation of dc motors is commonly available over a speed range of 8:1. Infinite range (smooth control down to zero speed) for short durations or reduced load is also common.
- Dc motors are often applied where they momentarily deliver three or more times their rated torque. In emergency situations, dc motors can supply over five times rated torque without stalling (power supply permitting).
- Dynamic braking (dc motor-generated energy is fed to a resistor grid) or regenerative



braking (dc motor-generated energy is fed back into the dc motor supply) can be obtained with dc motors on applications requiring quick stops, thus eliminating the need for, or reducing the size of, a mechanical brake

- Dc motors feature a speed, which can be controlled, smoothly down to zero, immediately followed by acceleration in the opposite direction without power circuit switching. And dc motors respond quickly to changes in control signals due to the dc motor's high ratio of torque to inertia.

- DC motors are used in many, if not most, modern machines.

Obvious uses would be in rotating machines such as fans, turbines, drills, the wheels on electric cars, locomotives and conveyor belts. Also, in many vibrating or oscillating machines, a dc motor spins an irregular figure with more area on one side of the axle than the other, causing it to appear to be moving up and down.

- DC motors are also popular in robotics. They are used to turn the wheels of vehicular robots, and servo motors are used to turn arms and legs in humanoid robots. In flying robots, along with helicopters, a motor causes a propeller or wide, flat blades to spin and create lift force, allowing vertical motion.
- DC motors are replacing hydraulic cylinders in airplanes and military equipment.
- In industrial and manufacturing businesses, DC motors are used to turn saws and blades in cutting and slicing processes, and to spin gears and mixers (the latter very common in food manufacturing). Linear motors are often used to push products into containers horizontally.
- Many kitchen appliances also use DC motors. Food processors and grinders spin blades to chop and break up foods. Blenders use electric motors to mix liquids, and microwave ovens use motors to turn the tray food sits on. Toaster ovens also use electric motors to turn a conveyor to move food over heating elements.

Hence the different aspects of DC motors can be familiar and well

## RELAYS

A **relay** is an electrically operated switch. Many relays use an electromagnet to mechanically operate a switch, but other operating principles are also used, such



as solid-state relays. Relays are used where it is necessary to control a circuit by a low-power signal (with complete electrical isolation between control and controlled circuits), or where several circuits must be controlled by one signal.

## History

The American scientist Joseph Henry invented a relay in 1835 in order to improve his version of the electrical telegraph, developed earlier in 1831.

It is claimed that the English inventor Edward Davy "*certainly invented the electric relay*" in his electric telegraph c.1835.

A simple device, which we now call a relay, was included in the original 1840 telegraph patent of Samuel Morse. The mechanism described acted as a digital amplifier, repeating the telegraph signal, and thus allowing signals to be propagated as far as desired. This overcame the problem of limited range of earlier telegraphy schemes.

The word *relay* appears in the context of electromagnetic operations from 1860

## BASIC DESIGN AND OPERATION

A simple electromagnetic relay consists of a coil of wire wrapped around a soft iron core, an iron yoke which provides a low reluctance path for magnetic flux, a movable iron armature, and one or more sets of contacts (there are two in the relay pictured). The armature is hinged to the yoke and mechanically linked to one or more sets of moving contacts. It is held in place by a spring so that when the relay is de-energized there is an air gap in the magnetic circuit. In this condition, one of the two sets of contacts in the relay pictured is closed, and the other set is open.

When an electric current is passed through the coil it generates a magnetic field that activates the armature, and the consequent movement of the movable contact(s) either makes or breaks (depending upon construction) a connection with a fixed contact. If the set of contacts was closed when the relay was de-energized, then the movement opens the contacts and breaks the connection, and vice versa if the contacts were open. When the current to the coil is switched off, the armature is returned by a force, approximately half as strong as the magnetic force, to its relaxed position. Usually this force is provided by a spring, but gravity is also used commonly in industrial motor starters. Most relays are manufactured to operate quickly.

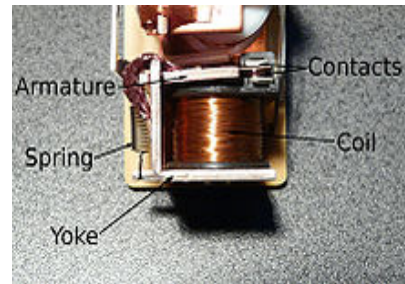

## Types

- Latching relay
- Reed relay
- Mercury-wetted relay
- Mercury relay
- Polarized relay
- Machine tool relay
- Ratchet relay
- Coaxial relay
- Contactor
- Solid-state relay
- Solid state contactor relay
- Buchholz relay
- Forced-guided contacts relay
- Overload protection relay
- Vacuum relays

## 3.6 POWER SUPPLY SECTION

The power supply circuits built using filters, rectifiers, and then voltage regulators. Starting with an ac voltage, a steady dc voltage is obtained by rectifying the ac voltage, then filtering to a dc level, and finally, regulating to obtain a desired fixed dc voltage. The regulation is usually obtained from an IC voltage regulator unit, which takes a dc voltage and provides a somewhat lower dc voltage, which remains the same even if the input dc voltage varies, or the output load connected to the dc voltage changes. The block diagram of power supply is shown in fig below.

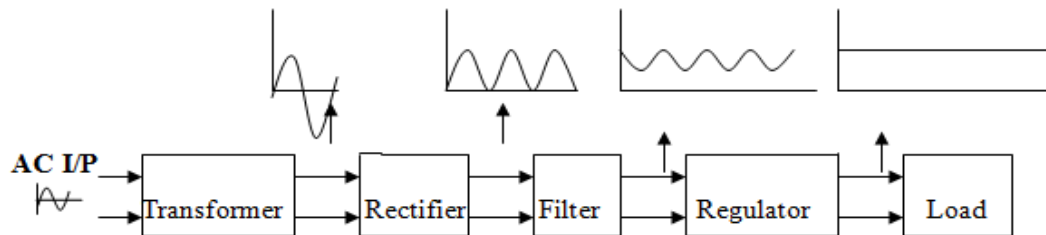

**Fig3.6.1: Block diagram of power supply**

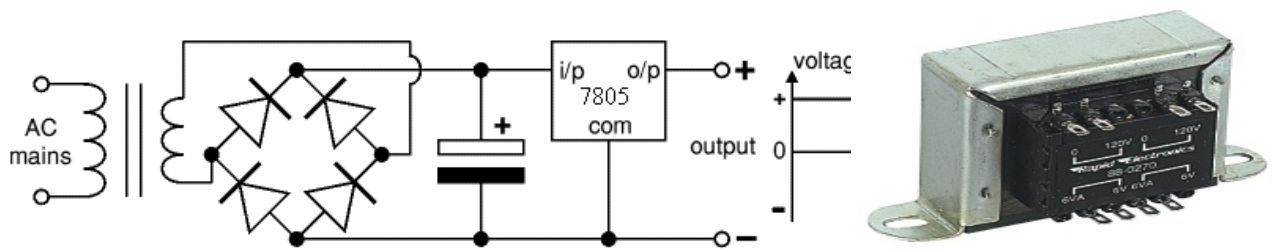

**Fig3.6.1.1: Circuit Diagram of power Supply**

**3.6.1 Transformers:** convert AC electricity from one voltage to another with little loss of power. Transformers work only with AC and this is one of the reasons why mains electricity is AC. Step-up transformer increase voltage, step-down transformer reduce voltage. Most power supplies use a step-down to reduce high mains voltage (230V ) to a safer voltage

### 3.6.2 Bridge Rectifier

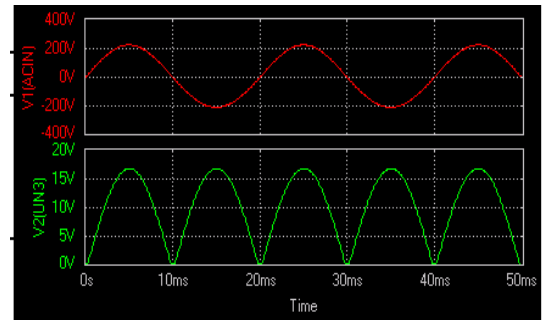
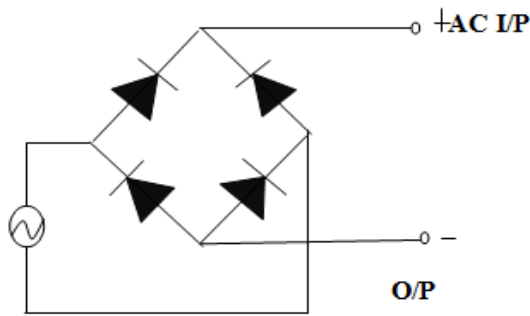

**Fig 3.34: Bridge rectifier and its output waveform**

The Bridge rectifier is a circuit, which converts an ac voltage to dc voltage using both half cycles of the input ac voltage. The Bridge rectifier circuit is shown in the figure. The circuit has four diodes connected to form a bridge. The ac input voltage is applied to the diagonally opposite ends of the bridge. The load resistance is connected between the other two ends of the bridge.

### 3.6.3 Capacitor Filter:

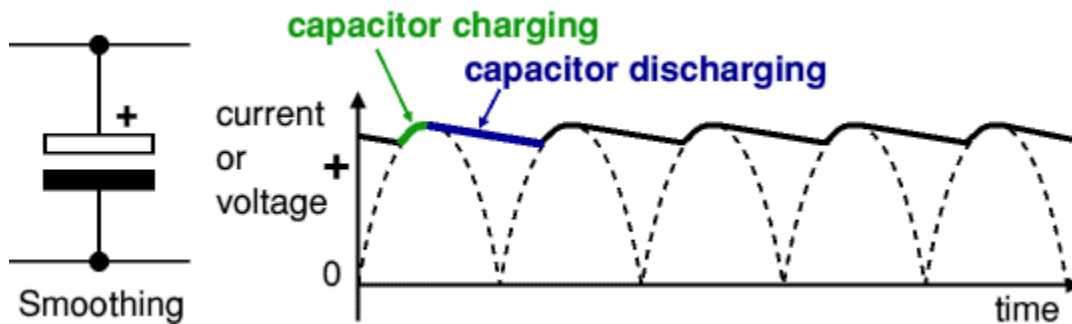

**Fig :3.6.3.1: Smoothing capacitor and its wave form**

The property of a capacitor is that it allows ac component and blocks dc component. The operation of the capacitor filter is to short the ripple to ground but leave the dc to appear at output when it is connected across the pulsating dc voltage.



During the positive half cycle, the capacitor charges up to the peak value of the transformer secondary voltage,  $V_m$  and will try to maintain this value as the full wave input drops to zero. Capacitor will discharge slowly until the transformer secondary voltage again increases to a value greater than the capacitor voltage. The diode conducts for a period, which depends on the capacitor voltage. The diode will conduct when the transformer secondary voltage becomes more than the diode voltage. This is called the cut in voltage. The diode stops conducting when the transformer voltage becomes less than the diode voltage. This is called cut-out voltage.

### 3.6.4 Voltage Regulators:

Fig shows the basic connection of a three-terminal voltage regulator IC to a load. The fixed voltage regulator has an unregulated dc input voltage,  $V_{in}$ , applied to one input terminal, a regulated output dc voltage,  $V_{out}$ , from a second terminal, with the third terminal connected to ground.

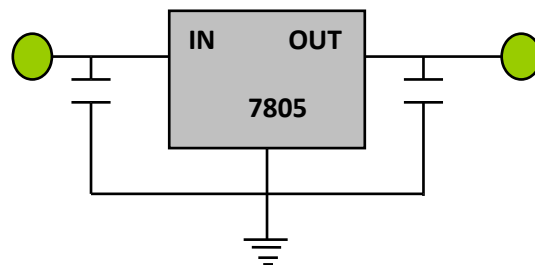

**Fig : 3.6.3.2:Fixed Voltage Regulator**

## 3.7 Liquid Crystal Display (LCD)

An LCD consists of two glass panels, with the liquid crystal material sandwiched in between them. The inner surface of the glass plates are coated with transparent electrodes which define the character, symbols or patterns to be displayed. Polymeric layers are present in between the electrodes and the liquid crystal, which makes the liquid crystal molecules to maintain a defined orientation angle.

One each polarisers are pasted outside the two glass panels. These polarisers would rotate the light rays passing through them to a definite angle, in a particular direction

When the LCD is in the off state, light rays are rotated by the two polarisers and the liquid crystal, such that the light rays come out of the LCD without any orientation, and hence the LCD appears transparent.

When sufficient voltage is applied to the electrodes, the liquid crystal molecules would be aligned in a specific direction. The light rays passing through the LCD would be rotated by the polarisers, which would result in activating / highlighting the desired characters.

The LCD's are lightweight with only a few millimeters thickness. Since the LCD's consume less power, they are compatible with low power electronic circuits, and can be powered for long durations.

The LCD's don't generate light and so light is needed to read the display. By using backlighting, reading is possible in the dark. The LCD's have long life and a wide operating temperature range. Changing the display size or the layout size is relatively simple which makes the LCD's more customer friendly.

### 3.7.1 Introduction:

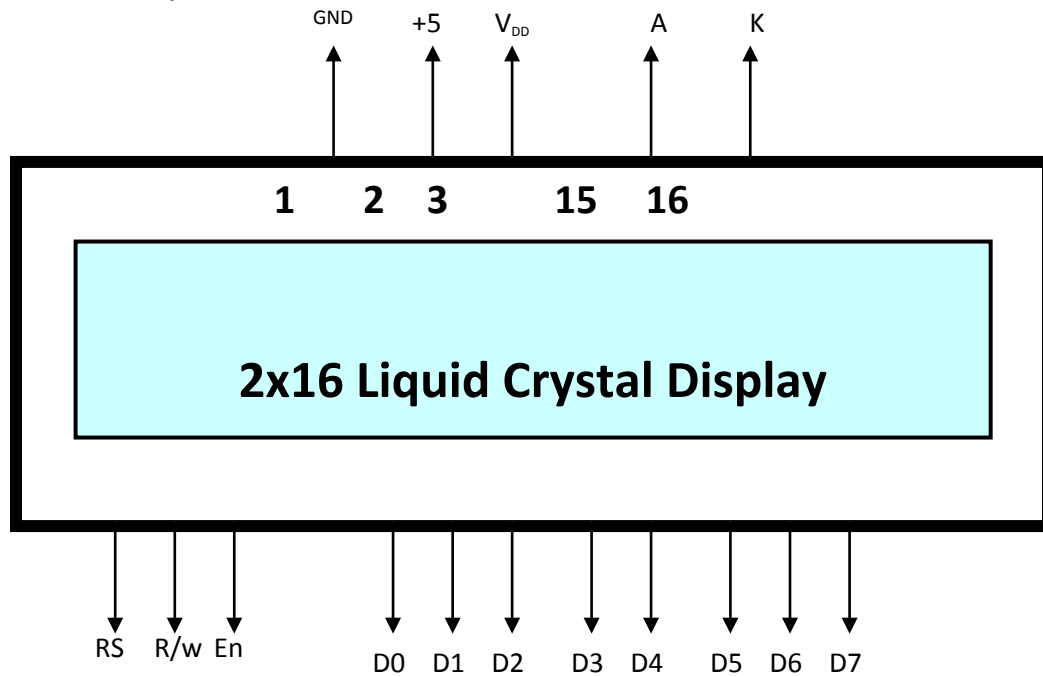

**Fig. LCD Display**

The LCD display consists of two lines, 20 characters per line that is interfaced with the PIC16F73. The protocol (handshaking) for the display is as shown in Fig. The display contains two internal byte-wide registers, one for commands (RS=0) and the second for characters to be displayed (RS=1). It also contains a user-programmed RAM area (the character RAM) that can be programmed to generate any desired character that can be formed using a dot matrix. To distinguish between these two data areas, the hex command byte 80 will be used to signify that the display RAM address 00h will be chosen Port1 is used to furnish the command or data type, and ports 3.2 to 3.4 furnish register select and read/write levels.

### 3.7.2 Pin Diagram

The Pin diagram for LCD is shown in the following fig 5.7 and the pin description is also explained in Table 5.





Pin No	Function	Name
1	Ground (0V)	Ground
2	Supply voltage; 5V (4.7V – 5.3V)	V <sub>CC</sub>
3	Contrast adjustment; through a variable resistor	V <sub>EE</sub>
4	Selects command register when low; and data register when high	Register Select
5	Low to write to the register; High to read from the register	Read/write



6	Sends data to data pins when a high to low pulse is given	Enable
7	8-bit data pins	DB0
8		DB1
9		DB2
10		DB3
11		DB4
12		DB5
13		DB6
14		DB7
15	Backlight V <sub>cc</sub> (5V)	Led+
16	Backlight Ground (0V)	Led-

### 3.8 Buzzer:

A **buzzer** or **beeper** is a audio signalling device, usually electronic, typically used in automobiles, household appliances such as a microwave oven, or game shows. It most commonly consists of a number of switches or sensors connected to a control unit that determines if and which button was pushed or a preset time has lapsed, and usually illuminates a light on the appropriate button or control panel, and sounds a warning in the form of a continuous or intermittent buzzing or beeping sound. Initially

this device was based on an electromechanical system which was identical to an electric bell without the metal gong (which makes the ringing noise).

Often these units were anchored to a wall or ceiling and used the ceiling or wall as a sounding board. Another implementation with some AC-connected devices was to implement a circuit to make the AC current into a noise loud enough to drive a loudspeaker and hook this circuit up to a cheap 8-ohm speaker. Nowadays, it is more popular to use a ceramic-based piezoelectric sounder like a Sonalert which makes a high-pitched tone. Usually these were hooked up to "driver" circuits which varied the pitch of the sound or pulsed the sound on and off



Types of buzzers

- Mechanical
- Electro mechanical
- Piezo electric

### **MECHANICAL**

A joy buzzer is an example of a purely mechanical buzzer.

### **ELECTRO MECHANICAL**

Early devices were based on an electromechanical system identical to an electric bell without the metal gong. Similarly, a relay may be connected to interrupt its own actuating current, causing the contacts to buzz. Often these units were anchored to a wall or ceiling to use it as a sounding board. The word "buzzer" comes from the rasping noise that electromechanical buzzers made.

### **PIEZOELECTRIC**



A piezoelectric element may be driven by an oscillating electronic circuit or other audio signal source, driven with a piezoelectric audio amplifier. Sounds commonly used to indicate that a button has been pressed are a click, a ring or a beep.

### **Uses**

- Annunciator panels
- Electronic metronomes
- Game shows
- Microwave ovens and other household appliances
- Sporting events such as basketball games
- Electrical alarms

### **3.8.3 LM358 Comparator:**

#### **3.8.3.1 Description:**

The LM358 consist of two independent, high gain, internally frequency compensated operational amplifiers which were designed specifically to operate from a single power supply over a wide range of voltage. Operation from split power supplies is also possible and the low power supply current drain is independent of the magnitude of the power supply voltage. Application areas include transducer amplifier, DC gain blocks and all the conventional OP-AMP circuits which now can be easily implemented in single power supply systems.

#### **3.8.3.2 Features:**

- Internally Frequency Compensated for Unity Gain
- Large DC Voltage Gain: 100dB
- Wide Power Supply Range: LM358 3V~32V (or  $\pm 1.5V \sim 16V$ )



- Input Common Mode Voltage Range Includes Ground
- Large Output Voltage Swing: 0V DC to  $V_{cc} - 1.5V$  DC
- Power Drain Suitable for Battery Operation.

### 3.8.3.3 Internal Block Diagram:

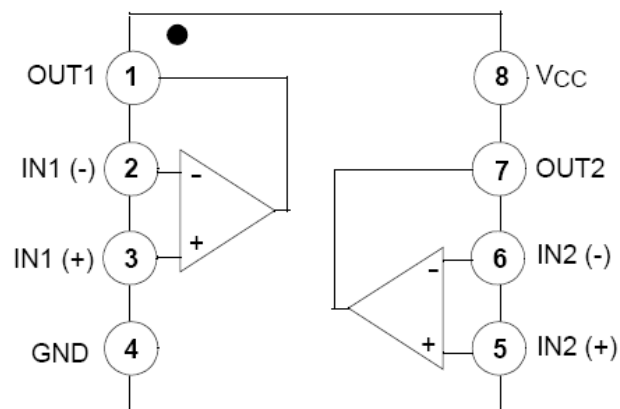





## **3.9 CIRCUIT DIAGRAM AND CODE**

### **3.9.1 CIRCUIT DIAGRAM**

LCD

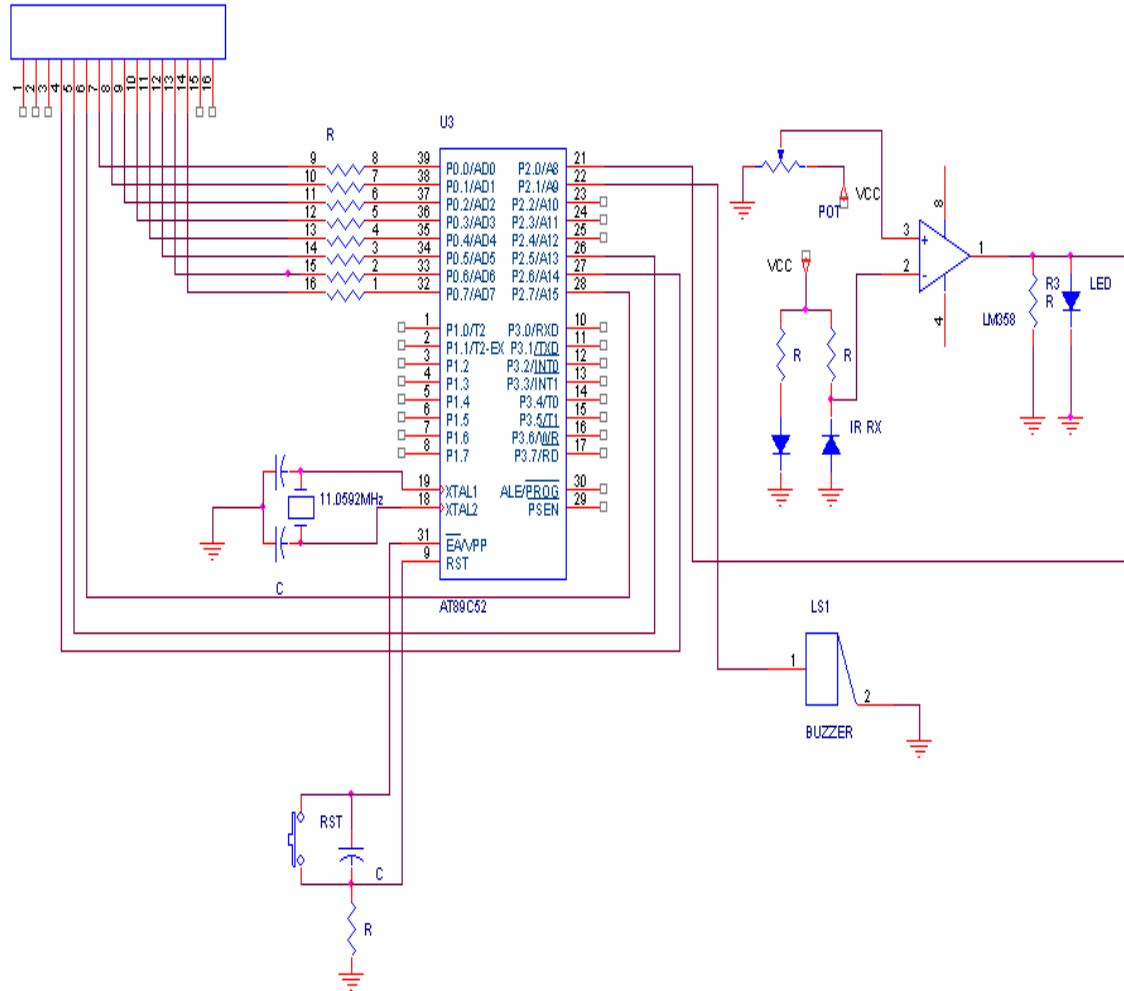

### Working operation.

the IR transmitter and IR receiver are placed in a straight line. The IR transmitter and IR receiver together form one input terminal of the comparator. The other input terminal is fixed or standard voltage. This terminal acts as a reference.

The IR transmitter will send the near IR rays on to the eye (say driver's eye). When the driver's eye is open, different portions of light absorb different amounts of light, so the IR receiver doesn't get any light back. So the output of the comparator will be 0V or logic 0.



When the drivers eye is closed,a substantial amount of ir light will be received by the ir receiver . Comparator compares it with the reference value and gives logic 0 when the voltage across one of the terminal is less than the standard value else logic one.

As and when the comparator output is high for a certain period of time(say 5 seconds),the micro controller triggers the buzzer,one of the motor which is already in motion will stop and other which is already idle will start rotating.it means a motor which represents the tyre of the vehicle will stop and the motor which represents seat vibrator will start.

In the LCD the message will be changed from “eye blink sensor detect,normal ok proceed” to “attention please take care.

If the driver awakes from sleep,that is the eye blink sensor output or the comparator output is low for certain amount of time,everything will restore.it means buzzer will be turned off,seat vibrator will be in rest,vehicle tyre will be in motion and the message in LCD will be”eye blink sensor detect,normal ok proceed”.

### 3.9.2 CODE

#### Source Code:

```
;THIS IS ir obstruction detector  
  
;P2.0 = BUZZ  
  
;P2 = DISP DATA
```



```
;P3.2 = RS
;P3.3 = R/W
;P3.2 = EN

;P1.0 = SENSOR
```

```
ORG 0
LJMP START
ORG 0050H
```

START:

```
CLR P1.1
CLR P1.2
```

```
LCALL LCDINI
```

```
LCALL SEC
```

```
MOV DPTR,#0900H
LCALL TLINE
MOV DPTR,#0910H
LCALL BLINE
```

```
LCALL SSEC
```

```
;***** READ STATUS *****
MAIN:  SETB P1.1
      CLR P1.2
```

```
MOV DPTR,#0920H
LCALL TLINE
MOV DPTR,#0930H
LCALL BLINE
```

```
XXCC:  LCALL SEC
```

```
;SETB P1.2
LCALL IRCHK
CJNE R0,#01H,MAIN
```

```
MOV DPTR,#0940H
LCALL TLINE
MOV DPTR,#0950H
LCALL BLINE
```



```
SETB P1.2
LCALL SSEC
LCALL SEC
CLR P1.1
LCALL SSEC
LJMP XXCC

;*****

IRCHK:  MOV R0,#00H
        ;SETB P1.1
        LCALL DEL

KX0:    JB P1.0,KX1
        LCALL DDEL
        JB P1.0,KX0

KX1:    LCALL SEC
        LCALL SEC
        JB P1.0,KX2
        LCALL DDEL
        JB P1.0,KX1

KX2:    JB P1.0,KX3
        LCALL DDEL
        JB P1.0,KX2

        MOV R0,#01H
        ;CLR P1.1
        RET

KX3:    MOV R0,#00H
        ;CLR P1.1
        RET

;-----
;*****

DDEL:   MOV R5,#04H
EDR:    mov r4,#FFH
        djnz r4,$
        djnz r5,EDR
        RET

;***** LCD INI *****
LCDINI: CLR P3.2

        CLR P3.2
        CLR P3.3
        MOV P2,#30H
```



LCALL WRI

CLR P3.2  
CLR P3.3  
MOV P2,#30H  
LCALL WRI

CLR P3.2  
CLR P3.3

MOV P2,#30H  
LCALL WRI

CLR P3.2  
CLR P3.3  
MOV P2,#38H  
LCALL WRI

CLR P3.2  
CLR P3.3  
MOV P2,#01H  
LCALL WRI

CLR P3.2  
CLR P3.3  
MOV P2,#01H  
LCALL WRI

CLR P3.2  
CLR P3.3  
MOV P2,#01H  
LCALL WRI

CLR P3.2  
CLR P3.3  
MOV P2,#02H  
LCALL WRI

CLR P3.2  
CLR P3.3  
MOV P2,#0CH  
LCALL WRI

CLR P3.2  
CLR P3.3  
MOV P2,#1CH  
LCALL WRI

CLR P3.2



```
CLR P3.3
MOV P2,#38H
LCALL WRI
```

```
CLR P3.2
CLR P3.3
MOV P2,#06H
LCALL WRI
```

```
CLR P3.2
CLR P3.3
MOV P2,#01H
LCALL WRI
```

```
RET
```

```
;-----
TLINE:  CLR P3.2
        CLR P3.3
        MOV P2,#80H
        LCALL WRI
        MOV R7,#00H
```

```
TKL:    CLR A
        MOVC A,@A+DPTR
        MOV P2,A
        LCALL WRD
        INC DPTR
        INC R7
        CJNE R7,#10H,TKL
        RET
```

```
;-----
BLINE:  CLR P3.2
        CLR P3.3
        MOV P2,#C0H
        LCALL WRI
        MOV R7,#00H
```

```
BKL:    CLR A
        MOVC A,@A+DPTR
        MOV P2,A
        LCALL WRD
        INC DPTR
        INC R7
        CJNE R7,#10H,BKL
        RET
```

```
;***** INSTRUCTION /DATA WRITE *****
```

```
WRI:    SETB P3.4
        MOV R0,#FFH
```



```
DJNZ R0,$
CLR P3.4
MOV R0,#FFH
DJNZ R0,$

RET

WRD:  SETB P3.2 ; REGISTER
      CLR P3.3 ;READ WRITE
      SETB P3.4 ;ENABLE
      MOV R0,#FFH
      DJNZ R0,$
      CLR P3.4
      CLR P3.3
      CLR P3.2
      RET
;*****

DEL:   MOV R7,#FFH
      DJNZ R7,$
      RET

DEL1:  MOV R7,#FFH
      DJNZ R7,$
      RET

SEC:   MOV R5,#0AH
M1:    MOV R6,#FFH
M2:    MOV R7,#FFH
M3:    DJNZ R7,M3
      DJNZ R6,M2
      DJNZ R5,M1
      RET

SSEC:  MOV R5,#1FH
SM1:   MOV R6,#FFH
SM2:   MOV R7,#FFH
SM3:   DJNZ R7,SM3
      DJNZ R6,SM2
      DJNZ R5,SM1
      RET
;*****

      ORG 0900H
;***** 1 LINE

DB ' EYE BLINK '
DB ' SENSOR DETECT '
```





```
DB ' NORMAL OK      '  
DB ' PLEASE PROCEED '
```

```
DB ' ATTENTION PL.  '  
DB ' TAKE CARE      '
```

```
;-----  
END;
```

```
;AAAAAAAAAAAAAAAAAAAAAAAAAAAAAAAAAAAAAAAAAAAAAAAAAAAAAAAAAAAA
```

# CHAPTER 4

## SOFTWARE

Proteus is a software used for micro processor simulation,schematic capture and printed circuit board(PCB) design.It is developed by lab centre electronics

### 4.1 system components

The **ISIS schematic capture** –a tool for entering designs.



### **PROSPICE Mixed Mode SPICE-**

Simulation-industry standard SPICE3F5 simulator combined with a digital simulator.

**ARES PCB Layout**-PCB design system with automatic component placer,rip-up and retry auto-router and interactive design rule checking.

**VSM**-virtual system modelling lets co-simulate embedded software for popular micro controllers alongside hardware design.

**System Benefits**-Integrated package with common user interface and fully context sensitive help.

### **Overview**

Proteus PCB design combines the ISIS schematic capture and ARES PCB layout programs to provide a powerful, integrated and easy to use suite of tools for professional PCB Design. All Proteus PCB design products include an integrated shape based autorouter and a basic SPICE simulation capability as standard. More advanced routing modes are included in Proteus PCB Design Level 2 and higher whilst simulation capabilities can be enhanced by purchasing the Advanced Simulation option and/or micro-controller simulation capabilities

### **USB SAP:**

To dump the code in to AT89S52,a software programmer called USB SAP was used.

It is suitable for AT89SXX micro controllers

## **CHAPTER 5**



# RESULTS

## Result

An embedded application is designed and implemented for alerting the driver when the driver is in sleep. In this, the output of the ir sensor (digital form) is used to control the buzzer, dc motors and display.

A mechanism has been developed such that when the output of the ir is high for a minimal time, the buzzer will ring, one of the dc motor will stop and the other will start. Simultaneously a message will be displayed in lcd representing the condition of the driver.

Conclusion

### 6.1 CONCLUSION:

The project aimed at developing a prototype. The prototype has been developed using 8052 microcontroller.

We have successfully implemented the idea of prevention of accidents by eye blinking detection methods. The eye blink sensor detects whether the driver is sleeping or not. If the driver is sleeping, the IR sensor output is HIGH, Alarm input is HIGH. Then alarm will ring continuously until the IR sensor output is LOW. If the Ir sensor output is continuously high, the vehicle will stop immediately.

We can increase the range of IR sensor by using high sensitivity IR sensors. Care should be taken while selecting the sensors to ensure that the required time to retrieve the data is small to keep the processing time low.

### Future enhancements:

The prototype can be developed by:

Integrating a system which determines the car location and sends message if any accidents occurs. If the system fails unfortunately and the vehicle undergoes any



accident, then it has to give an alarm sound and also has to send the message along with the location to the nearest rescue team.

Integrating with the alcohol detection sensor and making small modifications will result in the control of DRUNK and DRIVE.

Incorporating a system to determine if the driver is late to take actions. If the driver is too late to take Decisions, the vehicle has to turn in to automatic mode and decelerates automatically. Deceleration of vehicle can be done by using pulse width modulation technique.

Integrating a tyre pressure monitoring System which indicates the pressure in all tyres in the display which is present in front of the driver. By using this we can avoid burst of tyre.

## **BIBOLOGY**

<http://www.azosensors.com/Article.aspx?ArticleID=339>

[http://www.alibaba.com/product-detail/12v-dc-motor-specifications\\_720371056.html?s=p](http://www.alibaba.com/product-detail/12v-dc-motor-specifications_720371056.html?s=p)

<http://www.ustudy.in/node/7508>



<http://en.wikipedia.org/>

<http://seminarprojects.com/>

<http://en.wikipedia.org/wiki/Buzzer>